

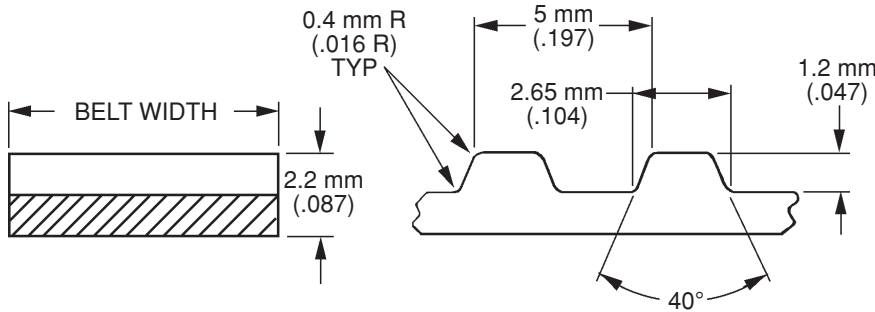

T5 Timing Belts



Pitch 5 mm (.197")



MATERIAL:
Nylon Covered, Fiberglass Reinforced, Neoprene

LOADING CAPACITY:
60 N/mm (343 lbf/in.) Belt Width

BREAKING STRENGTH:
≥80 N/mm (457 lbf/in.) Belt Width

TEMPERATURE RANGE:
-40°C to 120°C (-40°F to 248°F)

QB-T5 – □ □ □ □ – □ □

PITCH LENGTH CODE

WIDTH CODE	Belt* Width
06	6 mm (.236)
10	10 mm (.394)
16	16 mm (.630)
25	25 mm (.984)

PITCH LENGTH CODE	Pitch Length		No. of Teeth
	mm	Inch	
0115	115	4.528	23
0150	150	5.906	30
0165	165	6.496	33
0185	185	7.283	37
0200	200	7.874	40
0210	210	8.268	42
0215	215	8.465	43
0220	220	8.661	44
0225	225	8.858	45
0240	240	9.449	48
0250	250	9.843	50
0255	255	10.039	51
0260	260	10.236	52
0270	270	10.630	54
0275	275	10.827	55
0280	280	11.024	56
0295	295	11.614	59
0300	300	11.811	60
0305	305	12.008	61
0310	310	12.205	62
0325	325	12.795	65
0330	330	12.992	66
0340	340	13.386	68

PITCH LENGTH CODE	Pitch Length		No. of Teeth
	mm	Inch	
0350	350	13.780	70
0355	355	13.976	71
0365	365	14.370	73
0375	375	14.764	75
0390	390	15.354	78
0400	400	15.748	80
0410	410	16.142	82
0420	420	16.535	84
0425	425	16.732	85
0450	450	17.717	90
0455	455	17.913	91
0475	475	18.701	95
0480	480	18.898	96
0500	500	19.685	100
0505	505	19.882	101
0510	510	20.079	102
0525	525	20.669	105
0545	545	21.457	109
0550	550	21.654	110
0560	560	22.047	112
0570	570	22.441	114
0575	575	22.638	115
0600	600	23.622	120

PITCH LENGTH CODE	Pitch Length		No. of Teeth
	mm	Inch	
0610	610	24.016	122
0620	620	24.409	124
0630	630	24.803	126
0635	635	25.000	127
0650	650	25.591	130
0665	665	26.181	133
0675	675	26.575	135
0685	685	26.969	137
0690	690	27.165	138
0700	700	27.559	140
0710	710	27.953	142
0720	720	28.346	144
0725	725	28.543	145
0740	740	29.134	148
0750	750	29.528	150
0780	780	30.709	156
0800	800	31.496	160
0805	805	31.693	161
0810	810	31.890	162
0815	815	32.087	163
0840	840	33.071	168
0850	850	33.465	170
0860	860	33.858	172

*Special Widths - cut to size from sleeves available from stock.

Continued on the next page





T5 Timing Belts



Pitch 5 mm (.197")

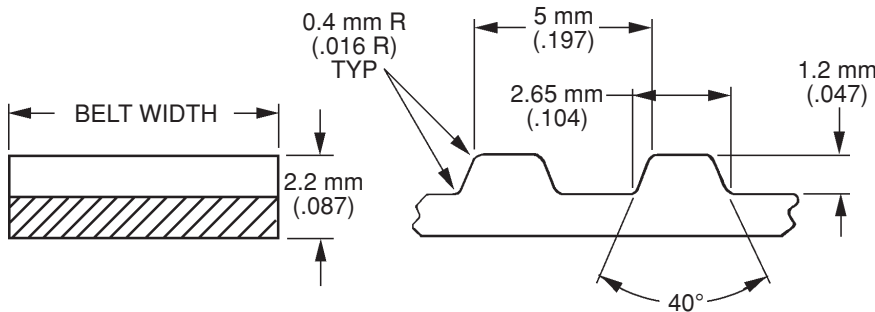

MATERIAL:
Nylon Covered, Fiberglass Reinforced, Neoprene

LOADING CAPACITY:
60 N/mm (343 lbf/in.) Belt Width

BREAKING STRENGTH:
≥80 N/mm (457 lbf/in.) Belt Width

TEMPERATURE RANGE:
-40°C to 120°C (-40°F to 248°F)

QB-T5 – –

PITCH LENGTH CODE

WIDTH CODE	Belt* Width
06	6 mm (.236)
10	10 mm (.394)
16	16 mm (.630)
25	25 mm (.984)

PITCH LENGTH CODE	Pitch Length		No. of Teeth
	mm	Inch	
0900	900	35.433	180
0940	940	37.008	188
0990	990	38.976	198
0995	995	39.173	199
1000	1000	39.370	200
1020	1020	40.157	204
1030	1030	40.551	206
1045	1045	41.142	209
1050	1050	41.339	210
1060	1060	41.732	212
1075	1075	42.323	215
1100	1100	43.307	220
1120	1120	44.094	224
1140	1140	44.882	228
1200	1200	47.244	240
1215	1215	47.835	243
1260	1260	49.606	252
1270	1270	50.000	254
1300	1300	51.181	260
1380	1380	54.331	276

PITCH LENGTH CODE	Pitch Length		No. of Teeth
	mm	Inch	
1390	1390	54.724	278
1415	1415	55.709	283
1520	1520	59.843	304
1630	1630	64.173	326
1760	1760	69.291	352
1800	1800	70.866	360
1880	1880	74.016	376
1900	1900	74.803	380
1940	1940	76.378	388
1960	1960	77.165	392
2120	2120	83.465	424
2220	2220	87.402	444
2260	2260	88.976	452
2280	2280	89.764	456
3060	3060	120.472	612
3255	3255	128.150	651
3540	3540	139.370	708
3750	3750	147.638	750
4075	4075	160.433	815

*Special Widths - cut to size from sleeves available from stock.

